

Pi 2 Design

**Mercury Streamer
Hardware Reference Manual**

© 2022 PI 2 Design

Table of Contents

1	Warranty.....	3
2	Operating Specifications.....	4
2.1	Mercury Streamer Operating specifications.....	4
3	Overview.....	5
3.1	Introduction.....	5
3.2	Block Diagram.....	6
4	On-Board Devices.....	7
4.1	Overview.....	7
4.2	Compute Module 4.....	7
4.2	USB2504A usb hub.....	7
4.3	WM8804 SPDIF Transmitter.....	8
4.3.1	WM8804 SPDIF Transmitter Notes.....	8
4.4	Dual High Resolution NDK Clocks.....	8
4.5	RS-485 Differential Transmitter.....	8
4.6	I2S Parallel Buffer.....	9
4.7	I2S Differential Driver.....	9
4.8	Audio Data Rate LED's.....	9
5	CM4 Ports and GPIO.....	10
5.1	Overview.....	10
5.2	Compute Module 4 Ports.....	10
5.2.1	CM4 Port Notes.....	10
5.3	Compute Module 4 GPIO.....	11
5.3.1	CM4 GPIO Notes.....	12
6	Mercury Streamer Power.....	13
6.1	Overview.....	13
7	Mercury Streamer Software.....	15
8	Connector Locations.....	16
8.1	Overview.....	16
8.2	Front and Rear Panel and Interior Views.....	16
8.3	P1 – Expansion I/O Connector.....	18
8.3	P2 – Micro-USB, FACTORY USE ONLY.....	19
8.4	P3 – Console UART, FACTORY USE ONLY.....	19
8.5	P4 – HDMI 0.....	19
8.6	P5 – DSI.....	19
8.7	P6 – 5V Header, FACTORY USE ONLY.....	20
8.8	P7 – Dual USB.....	20
8.9	P8 – Gigabit Ethernet.....	20
8.10	P9 – M.2 2280 NVMe.....	20
8.11	P10 – BNC AES Single Ended.....	20
8.12	P11 – XLR AES Balanced.....	20
8.13	P12 – DC Input.....	20
8.15	P13 – Expansion Power Connector.....	20
8.15	P14 –USB.....	21
8.16	P15 – I2S Over HDMI.....	21
8.17	P16 HDMI 1.....	22
8.18	U15 – Combo RCA/Opto Transmitter.....	22
8.19	D7, D8 – Speed LED's.....	22
8.20	SD1 – Micro-SD Card.....	22
9	Document Revisions.....	23
10	Errata.....	24
10.15	Overview.....	24

List of Figures

Figure 1	– Mercury Streamer Block Diagram.....	6
Figure 2	– Mercury Streamer Power, Simplified Block Diagram.....	13
Figure 3	– Mercury Streamer Power Control Schematic.....	13
Figure 4	– Mercury Streamer Front Panel.....	16
Figure 4	– Mercury Streamer Rear Panel.....	17
Figure 4	– Mercury Streamer Internal View.....	18

1 WARRANTY

The enclosed product ("the Product") is warranted by Pi 2 Design for a period of one year for reasonable, individual home use, all as further described and defined below. This warranty runs solely to the individual purchasing the Product and is not transferable or assignable in any respect. This warranty is valid only for so long as the product is used intact as shipped from Pi 2 Design. Any attempt or effort to alter the Product, including but not limited to any attempt to solder, de-solder, unplug, replace, add or affix any part or component of or onto the Product, other than components specifically intended for the user to plug and unplug into appropriate sockets and/or Connectors to facilitate intended use and deployment, all as specifically described and authorized in this Product Hardware Reference Manual, shall void this warranty in all respects. Coverage under this warranty requires that the Product be used and stored at all times in conditions with proper electrostatic protection necessary and appropriate for a complex electronic device. These conditions include proper temperature, humidity, radiation, atmosphere and voltage (standard commercial environment, 0C to +70C, <60%RH). Any Product that has been modified without the express, prior written consent of Pi 2 Design is not covered by this warranty. The use or connection of any adapter or component with any device other than a Pi 2 Design Connector or adapter shall void this warranty and the warranty of all other components, parts and modules connected to the rest of the system. Pi 2 Design shall not be responsible for any damage to the Product as a result of a customer's use or application of circuitry not developed or approved by Pi 2 Design for use on or in connection with the Product.

This warranty does not cover defects caused by electrical or temperature fluctuations or from stress resulting from or caused by abuse, misuse or misapplication of the Product. Any evidence of tampering with the serial number on the Product shall immediately void this warranty. Notwithstanding anything to the contrary herein, Pi 2 Design expressly disclaims any implied warranty of merchantability or implied warranty of fitness for a particular purpose in connection with the manufacture or use of the Product.

2 OPERATING SPECIFICATIONS

2.1 MERCURY STREAMER OPERATING SPECIFICATIONS

The Mercury Streamer conforms to the following specifications:

Specification	Value
Dimensions	170mm x 123.2mm x 53.5mm (6.7" x 4.85" x 2.1")
Weight	~1kg (2 lbs.)
Storage Temperature	-20C to +85C (-4F to 185F)
Operating Temperature	0C to +70C (32F to 158F)
Humidity	0% to 95% RH, Non-Condensing
Input Voltage (VIN)	+12V +/- 20% DC
Power Consumption	3W Typical, 8W Maximum (not including SSD)

Table 1 – Mercury Streamer Operating Specifications

3 OVERVIEW

3.1 INTRODUCTION

The Mercury Streamer, designed and manufactured by PI 2 Design, is a Compute Module 4 based device designed for Professional, Studio Grade, Digital Audio Streaming. The Mercury Streamer converts the Compute Module 4 I2S Interface to High Definition Digital Audio Coax, OPTO and Balanced XLR. These multiple, simultaneously active digital audio outputs allow the Mercury Streamer to optimally interface with virtually any High Performance DAC on the market.

The major features of the Mercury Streamer are as follows:

- **COMPUTE MODULE 4** - This latest module from the Raspberry Pi Foundation provides 4 High Performance ARM Cores, Dual 4K HDMI Output, PCIe x1, Gigabit Ethernet and more.
- **M.2 2280 SSD** - A Standard M.2 Socket is provided for nVME Storage via the CM4 PCI Express x1 Link. The socket supports both "M" Key and "B" Key devices.
- **GIGABIT ETHERNET** - A standard RJ45 Provides the interface to the CM4 Gigabit Ethernet I/F.
- **DUAL EXTERNAL USB2.0** - This connector provides two USB2.0 Host Ports.
- **INTERNAL USB** - A vertical USB2.0 Connector is provided to interface with LCD Touch Screens for Internal display-based systems.
- **EXTERNAL HDMI** - One 4K HDMI Connector allows access to CM4 HDMI Output 0.
- **INTERNAL HDMI** - A vertical HDMI connector allows access to CM4 HDMI Output 1 for Internal display-based systems.
- **AES TRANSMITTER** – The industry standard WM8804 converts the CM4 I2S stream to AES3/SPDIF formatted data at 24-Bit up to 192Khz Frame Rate
- **AES COAX OUTPUT** – A 1:1 Isolation Transformer provides Bit Perfect Impedance Controlled Coaxial Transmission of the Digital Audio Data @1V AES Standard Level.
- **AES BALANCED OUTPUT** – An RS-485 Transmitter coupled with a 1:1 Isolation Transformer allows the transmission of balanced audio data via the Professional Audio Standard XLR Connector
- **TOSLINK OPTICAL OUTPUT** – Isolated Optical Transmitter Drives Consumer Level DAC's
- **SPDIF COAX OUTPUT** - A 1:1 Isolation Transformer provides Bit Perfect Impedance Controlled Coaxial Transmission of the Digital Audio Data @0.6V Consumer Standard Level.
- **DIFFERENTIAL I2S OUTPUT** – An LVDS Differential Transmitters is used to drive the I2S Bus over a standard HDMI Connector. The Pinout conforms to the PS Audio Standard.
- **HIGH RESOLUTION CLOCKS** – A pair of Ultra-Low Noise NDK NZ2520SDA oscillators allow the WM8804 to operate in non-PLL mode for the lowest possible noise.
- **ULTRA-LOW NOISE LDO's** – Separate Ultra-Low Noise LT3042 LDO's (0.9 uV noise and 80 dB PSRR) are used to supply the WM8804 Transmit Section and the NDK Clock's. Additionally, these are fed from an LT2941 LDO used as a 5V pre-regulator. This allows the entire power chain to be linear (assuming an external linear supply is used).
- **LOW NOISE PCB LAYOUT** – Constructed with 4-layer Split Ground PCB with noise reduction techniques refined from years of High-Speed Mixed-Signal Design work.
- **EXTRUDED ALUMINUM ENCLOSURE** – Rugged, Aircraft Grade Aluminum, Anodized for Scratch Resistance

3.2 BLOCK DIAGRAM

Refer to the following figure for a block diagram of the Mercury Streamer.

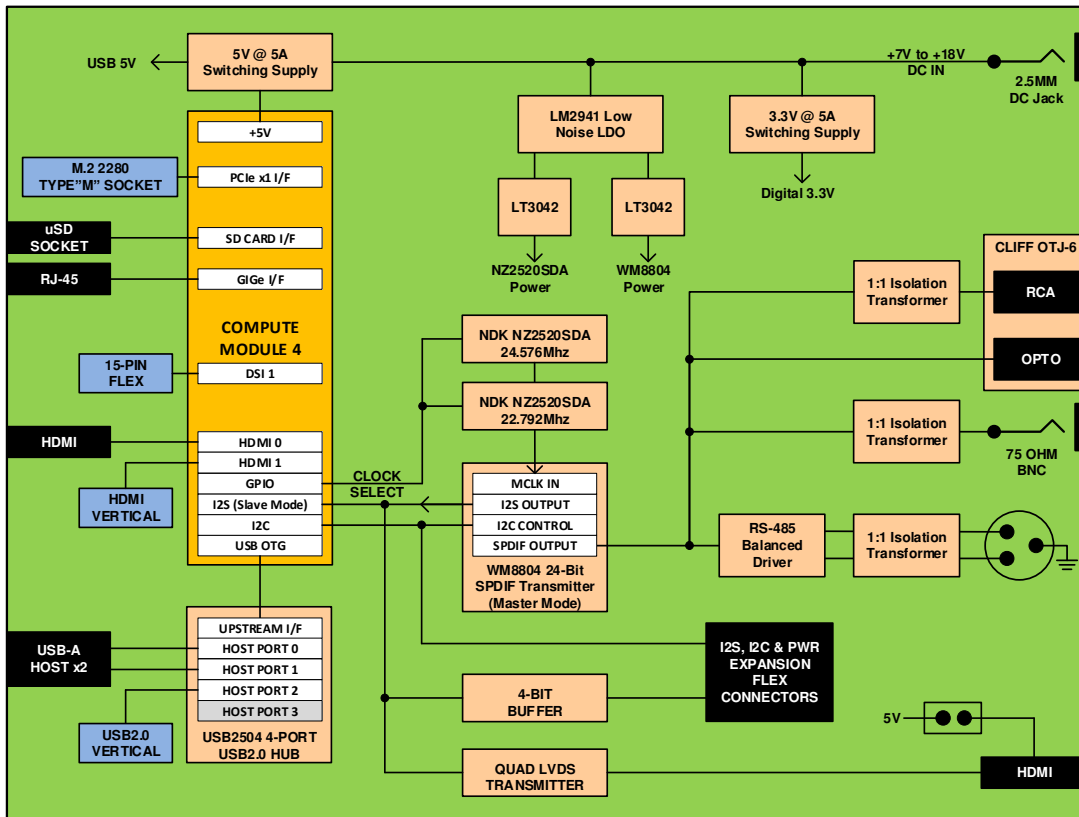

Figure 1 – Mercury Streamer Block Diagram

4 ON-BOARD DEVICES

4.1 OVERVIEW

The Mercury Streamer interfaces to the CM4 via a pair of high density Hirose Connectors. This section describes in detail the devices located on the Mercury Streamer.

4.2 COMPUTE MODULE 4

At the core of the Mercury Streamer is the latest Raspberry Pi Compute Module 4. Designed for low-powered embedded applications, this module runs the software required to perform the Digital Audio Player function as well as other applications. Key features of the CM4 (as used on the Mercury Streamer) are as follows:

- Broadcom BCM2711, Quad core Cortex-A72 (ARM v8) 64-bit SoC @ 1.5GHz
- H.265 (HEVC) (4Kp60 decode), H.264 (1080p60 decode, 1080p30 encode)
- OpenGL ES 3.0 graphics
- 4GB or 8GB LPDDR4-3200 SDRAM
- 2.4 GHz, 5.0 GHz IEEE 802.11 b/g/n/ac wireless
- Bluetooth 5.0, BLE
- Gigabit Ethernet PHY supporting IEEE 1588
- PCIe 1-lane Host, Gen 2 (5Gbps)
- USB 2.0 port
- UART, I2C and I2S Peripheral Ports
- Dual HDMI 2.0 ports (up to 4Kp60 supported)
- 4-lane MIPI DSI display port
- SDIO 2.0

4.2 USB2504A USB HUB

The Mercury Streamer uses the Microchip USB2504A to interface the CM4 with an external dual USB2.0 Connector and an internal, vertical USB2.0 Connector. The signals of the USB2504A and their use are described in the following table.

Signal	Connection	Description
USBD_N/P 0	CM4 USB_OTG	Upstream Host port from CM4
USBD_N/P 1	Unused	
USBD_N/P 2	P14	Internal Vertical USB Host Connector
USBD_N/P 3	P7 PORT A	Dual USB Host Connector, Lower Port
USBD_N/P 4	P7 PORT B	Dual USB Host Connector, Upper Port

Table 2 – USB2504A USB Hub Connections

4.3 WM8804 SPDIF TRANSMITTER

At the core of the Mercury Streamer is the Cirrus Logic WM8804 AES Digital Audio Transmitter. This device interfaces to the Compute Module 4 via I2S and I2C. The signals used to interface with the WM8804 are shown in the following table.

WM8804 Signal	CM4 Signal	Description
MCLK	-	Unused
BCLK	BCLK	I2S Bit Clock Output to Pi
LRCLK	LRCLK	I2S Word Clock Output to Pi
SDIN	SDOUT	I2S Serial Audio Data Input from Pi
SCL	SCL	I2C Clock from Pi
SDA	SDA	I2C Data to/from Pi
XIN	GPIO6	0 = Select 22.5792Mhz Input Clock for 44.1Khz, 88.2Khz and 176.4Khz Frame Rates 1 = Select 24.576Mhz Input Clock for 48Khz, 92Khz and 192Khz Frame Rates
TXO	-	AES3/SPDIF encoded digital audio output

Table 3 – CM4 to WM8804 Connections

4.3.1 WM8804 SPDIF TRANSMITTER NOTES

1. The WM8804 is controlled using the I2C port. Refer to the WM8804 documentation and installed player software.
2. The Mercury Streamer is designed to operate the WM8804 in Master mode. In this mode the WM8804 receives its master clock from XIN and drives MCLK (unused by the CM4), BCLK and LRCLK out. Serial Data in is received from CM4.

4.4 DUAL HIGH RESOLUTION NDK CLOCKS

A pair of NDK NZ2520SDA Ultra-Low Noise clocks provide the critical timing signals for the WM8804. They are selected via Compute Module 4 GPIO6 (0 = 22.5792Mhz and 1 = 24.576Mhz).

4.5 RS-485 DIFFERENTIAL TRANSMITTER

An RS-485 Differential Transmitter accepts the SPDIF output from the WM8804 and

sends it as a balanced pair to the 1:1 Isolation Transformer and then to the XLR connector.

4.6 I2S PARALLEL BUFFER

A 4-Bit Buffer is used to drive the I2S signals (MCLK, BCKL, LRCLK and SDO) to the I2S Expansion Flex Connector. This device is designed to drive the I2S Bus short distances (<12 inches).

4.7 I2S DIFFERENTIAL DRIVER

A Quad Differential LVDS Driver takes the I2S Bus and converts each signal into a balanced differential signal. This is then connected to an HDMI connector. This device is designed to drive the I2S Bus up to 3 meters.

4.8 AUDIO DATA RATE LED'S

Two LED's provide visual indication of the selected Audio Data Rate, 48/96/192Khz (Yellow) and 44.1/88.2/176.4Khz (Red).

5 CM4 PORTS AND GPIO

5.1 OVERVIEW

The Mercury Streamer uses several the Interface Ports and GPIO from the CM4 for control and status purposes.

5.2 COMPUTE MODULE 4 PORTS

Certain CM4 Port pins are hardwired and are always available when enabled. The usage for these ports on the Mercury Streamer are listed below in the following table.

PORT/Signal(s)	Mercury Streamer Use	Description
Ethernet	P8	RJ45 Ethernet Port
*LED_ACT	LED1	Green LED, CM4 Activity
*LED_PWR	LED2	Red LED, Power
Analog_IP0-1	Unused	
Camera_GPIO	Unused	
*EXT_RST	*RST	Reset Out to Peripherals
USB_P/N	USB2504A	USB Host to USB2504A Hub
USB_OTG_ID	USEL	Factory use only
CAM0-1	Unused	
DSI0	Unused	
DSI1	P5	DSI Interface for LCD Display
PCIe	P9	M.2 2280 NVMe Socket
HDMI0	P4	External HDMI Connector
HDMI1	P16	Internal, Vertical HDMI Connector
UART 1	P3	Serial Console

Table 4 – CM4 Ports and Usage

5.2.1 CM4 PORT NOTES

1. Ports marked unused are unavailable and not connected on the Mercury Streamer.
2. USB_OTG is used for factory programming of CM4 eMMC. This is only

used with CM4 modules that have built in eMMC. Non-eMMC modules use the SDIO port as the storage. USB_OTG Function is not available by default.

5.3 COMPUTE MODULE 4 GPIO

The CM4 provides a large number of General Purpose I/O (GPIO) pins. These pins also can be assigned to alternate functions as defined in the CM4 documentation. The usage of these pins (and alternate functions) on the Mercury Streamer are described in the following table.

GPIO	DIR	AF	PUP PDN	Mercury Streamer Usage	Description/Notes
0	I/O	I2C0	PUP	SDA0	Routed to P5 for DSI 0
1	I/O	I2C0	PUP	SCL0	Routed to P5 for DSI 0
2	I/O	I2C1	PUP	SDA	I2C Data for Mercury Streamer and Expansion
3	I/O	I2C1	PUP	SCL	I2C Clock for Mercury Streamer and Expansion
4	I/O			GPIO4	Routed to P1 Expansion Connector
5	I/O			GPIO5	Routed to P1 Expansion Connector
6	I/O			GPIO6	WM8804 Master Clock Select
7	-			unused	
8	-			unused	
9	-			unused	
10	-			unused	
11	-			unused	
12	-			unused	
13	-			unused	
14	OUT	UART1		TXD	Routed to P3 Header
15	IN	UART1		RXD	Routed to P3 Header
16	-			unused	
17	-			unused	

GPIO	DIR	AF	PUP PDN	Mercury Streamer Usage	Description/Notes
18	IN	I2S		BCLK	I2S Bit Clock from WM8804
19	IN	I2S		WCLK	I2S Word Clock from WM8804
20	-			unused	
21	OUT	I2S		SDOUT	I2S Serial Data to WM8804
22	OUT		PUP	PHLD	Power Hold to Power Circuit
23	IN		PUP	*ROT_SW	Rotary Center Switch, Routed to P17
24	IN		PUP	*PSW	Power On Switch from Power Circuit
25	IN		PUP	ROT_CK	Rotary Clock Switch, Routed to P17
26	IN		PUP	ROT_DT	Rotary Data Switch, Routed to P17
27	I/O			GPIO27	Routed to P1 Expansion Connector

Table 5 – CM4 Port and GPIO Pin Assignments

5.3.1 CM4 GPIO NOTES

3. DIR is from the point of view of the CM4.
4. Alternate Function (AF) column indicates that the use of this pin requires the pin to be assigned to the named function as defined by the CM4 specifications.
5. PUP/PDN indicates if the GPIO should have its associated Pullup (PUP) or Pulldown (PDN) resistor enabled.
6. An asterisk ‘*’ at the beginning of the name indicates a low true signal.

6 MERCURY STREAMER POWER

6.1 OVERVIEW

The Mercury Streamer is designed to be powered from an external +12V source. See the block diagram below for a simplified view of the Mercury Streamer power flow.

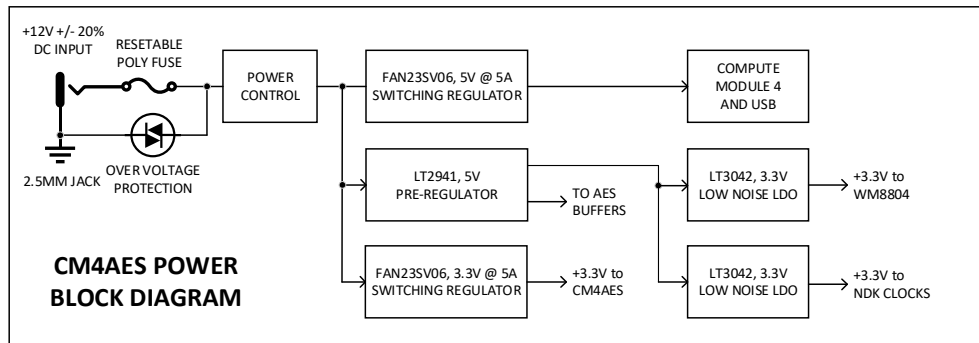

Figure 2 – Mercury Streamer Power, Simplified Block Diagram

6.2 POWER CONTROL

This circuit allows software to monitor and control the power state of the Mercury Streamer. It uses two GPIO to perform the Power Hold and Power State functions. This circuit is compatible with the Volumio 503HTA Plug-In. Note that by default the circuit simply follows the state of the Pushbutton Power Switch.

This circuit is shown in the figure below.

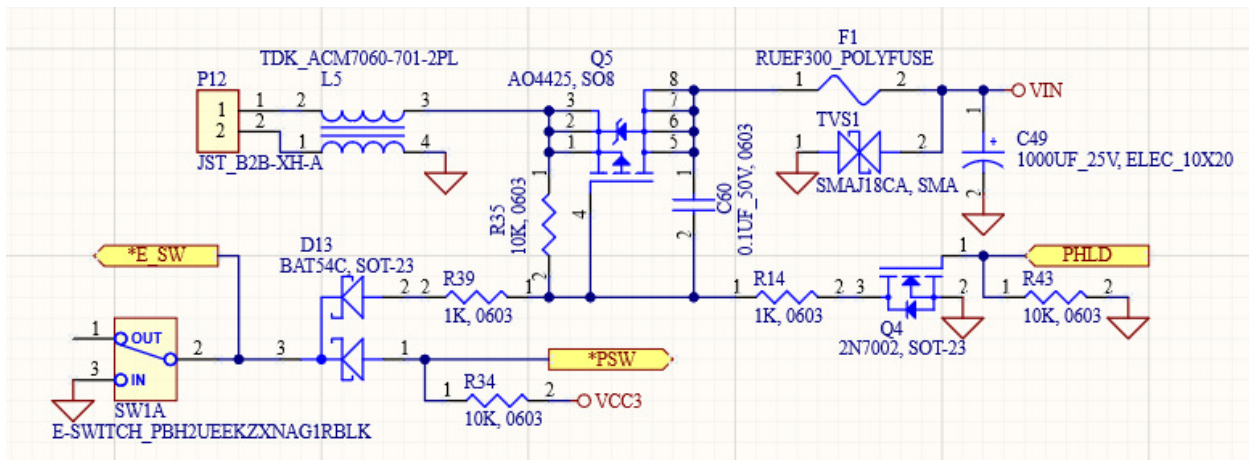

Figure 3 – Mercury Streamer Power Control Schematic

6.3 POWER STATUS

As part of the power control circuit, GPIO24 (*PSW) is used to sense the state of the Pushbutton Power Switch. A low indicates that the Power Switch is in the on position (depressed). When high it indicates that the user has placed the switch into the off position (non-depressed) thus opening the on/off switch. Note that for proper operation this circuit requires user software to program GPIO24 as an input with the internal pullup enabled.

6.4 POWER HOLD

GPIO22 (PHLD) allows the CM4 to hold the power on even after the user puts the Power Switch into the off position. After initialization, software can drive GPIO22 high, thus holding the power on regardless of the state of the on/off switch. Driving this low, removes this hold condition. Note that for proper operation this requires user software to program GPIO24 as an output with the internal pullup disabled.

7 MERCURY STREAMER SOFTWARE

7.1 OVERVIEW

Due to the various resources interfaced on the Mercury Streamer, both internal and external to the CM4, it is necessary to initialize a large number of CPU registers and external devices before correct operation can begin. These values and their proper sequencing are beyond the scope of this document.

7.2 COMPATIBLE DRIVER

Most Audio Player software will support Mercury using either the “Pi2design PI2AES” or “HifiBerry Digi+ Pro” driver.

7.3 USB HOST

Unlike the Raspberry Pi 4, the CM4 ROM Firmware does not enable the USB Host functionality by default. It is necessary to initialize this by adding the following line to `cfg_boot.txt`. Note that some player software will over-write this during an update but may offer an alternate location that is safe from updates.

To enable the USB 2.0 ports on the Compute Module 4, you need to edit the boot config file (`/boot/config.txt`) and add:

```
dtoverlay=dwc2,dr_mode=host
```

7.4 PCIE SSD CONFIGURATION

This section is %TBD%

8 CONNECTOR LOCATIONS

8.1 OVERVIEW

This section provides the type, location, and pinout for the various connectors on the Mercury Streamer.

8.2 FRONT AND REAR PANEL AND INTERIOR VIEWS

This shows the front and rear panels of the Mercury Streamer as well as an internal view of the PCB.

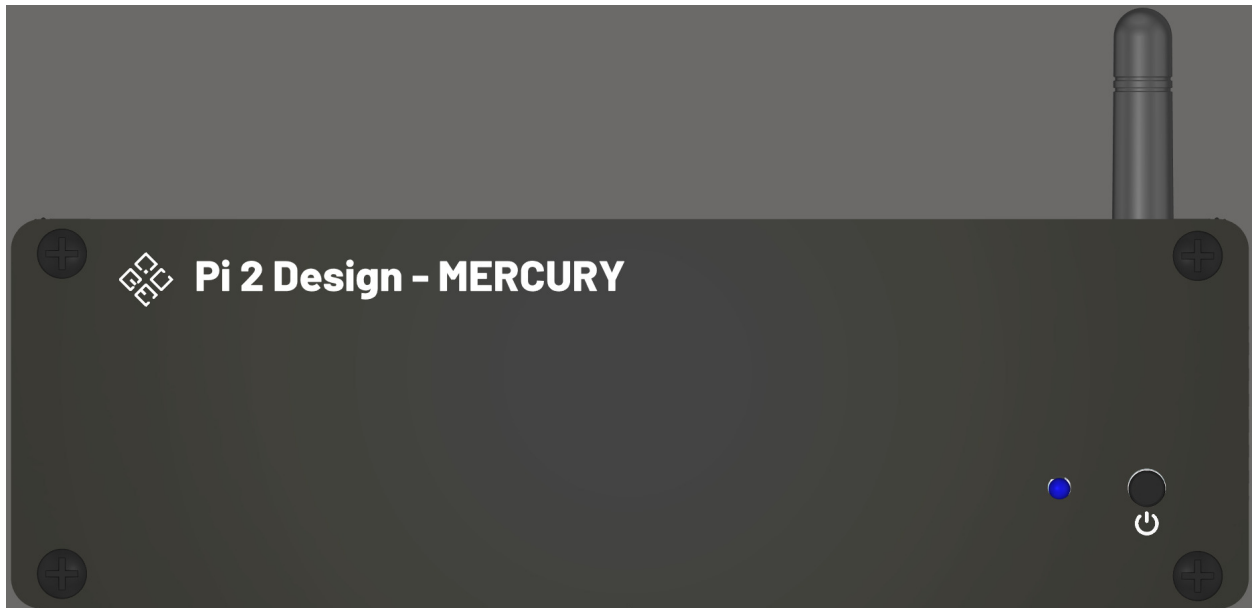

Figure 4 – Mercury Streamer Front Panel

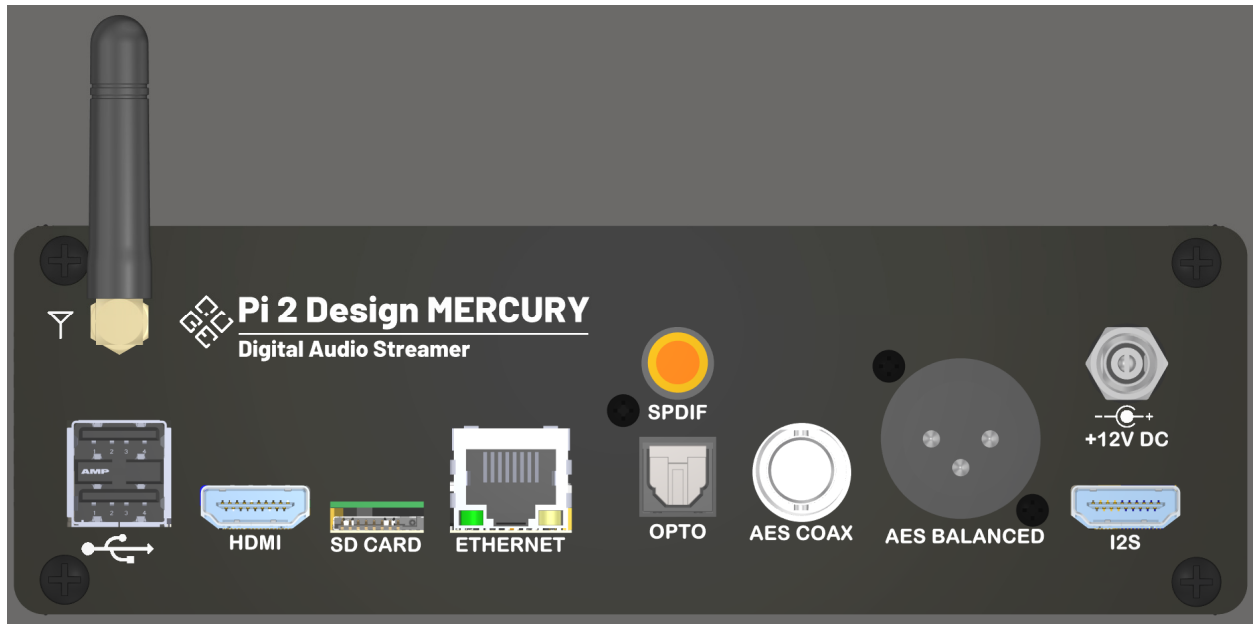

Figure 5 – Mercury Streamer Rear Panel

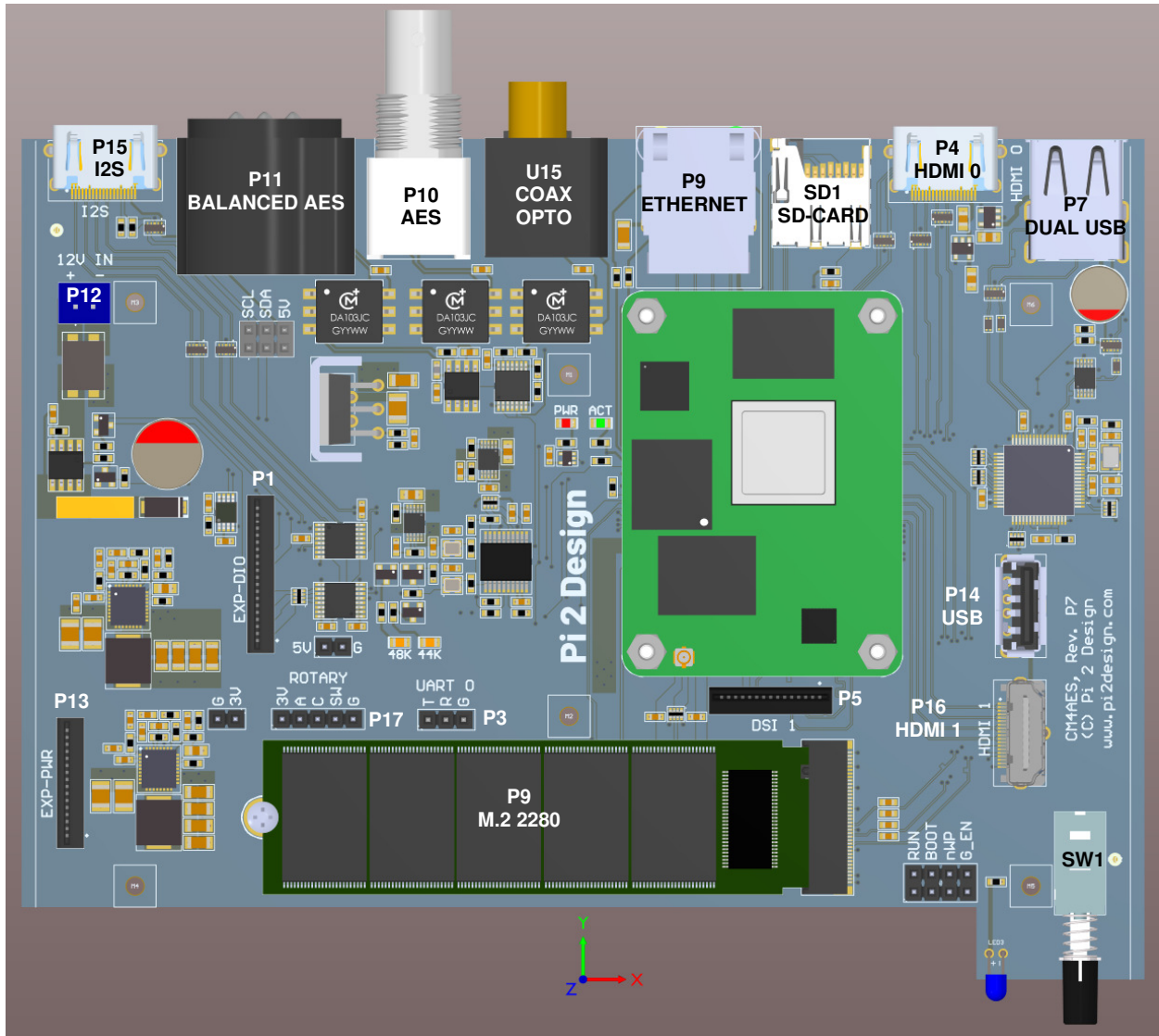

Figure 6 – Mercury Streamer Internal View

8.3 P1 – EXPANSION I/O CONNECTOR

P1 is an Amphenol HLW20S-2C7LF 20-Pin 1MM Pitch Flex connector. The Pinout for P1 is shown in the following table.

P1 PIN	Name	Description
1	MCLK	Buffered I2S Master Clock
2	GND	Ground
3	BCLK	Buffered I2S Bit Clock
4	GND	Ground

5	LRCLK	Buffered I2S Left/Right (Word) Clock
6	GND	Ground
7	SDO	Buffered I2S Data
8	GND	Ground
9	RSVD	Connected to CM4 GPIO20
10	*PSW	Power Enable – Low True
11	RSVD	Connected to CM4 GPIO27
12	*RST	Reset from CM4
13	RSVD	Connected to CM4 GPIO4
14	RSVD	Connected to CM4 GPIO5
15	GND	Ground
16	SCL	I2C Clock
17	SDA	I2C Data
18	*ALED	Connected to CM4 Activity LED Signal
19	*PLED	Connected to CM4 Power LED Signal
20	GND	Ground

Table 6 – Expansion I/O Connector Pinout

8.3 P2 – MICRO-USB, FACTORY USE ONLY

P2 is a standard USB2.0 Micro-B connector and conforms to the industry standard USB2.0 Pinout. It is connected to the CM4 USB OTG Port via a 2:1 switch. It is provided to allow programming of CM4 modules with built-in eMMC. It is not used for modules that have no eMMC. This connector is not populated by default.

8.4 P3 – CONSOLE UART, FACTORY USE ONLY

P3 is a 3x1 2.54mm pitch, single row connector It is connected to CM4 UART 1. Pinout is: Pin1 - TXD (GPIO14); Pin 2 – RXD (GPIO15); and Pin 3 – GND. Note these are TTL level and have no ESD protection.

8.5 P4 – HDMI 0

P4 is a standard right angle HDMI female connector and conforms to the industry standard HDMI Pinout. It is connected to CM4 HDMI Port 0.

8.6 P5 – DSI

P4 is an Amphenol HLW20S-2C7LF 20-Pin 1MM Pitch Flex connector and conforms to

the CM4 DSI Pinout. It is connected to CM4 DSI Port 1.

8.7 P6 – 5V HEADER, FACTORY USE ONLY

P6 is a 2x1 2.54mm pitch, single row connector It is connected to the on-board +5V Switch Supply. Pinout is: Pin1 - +5V; Pin 2 – GND.

8.8 P7 – DUAL USB

P7 is a standard Dual USB2.0 Host connector and conforms to the industry standard USB2.0 Pinout. It is connected to the USB2504A USB Hub, Ports 3 (top) and 4 (bottom).

8.9 P8 – GIGABIT ETHERNET

P8 is a standard RJ45 and conforms to the industry Pinout. It is connected to the CM4 Ethernet Port.

8.10 P9 – M.2 2280 NVME

P9 is an industry standard M.2 Connector. The supported NVMe modules are 2280 (22mm x 80mm), “M” or “B” keyed. It is connected to the CM4 PCIe Port.

8.11 P10 – BNC AES SINGLE ENDED

P10 is a right-angle BNC Female. This 75-ohm connector carries the Single Ended AES Digital Audio output.

8.12 P11 – XLR AES BALANCED

P3 is a 3-Pin XLR Connector. This 100-ohm connector carries the Balanced AES Digital Audio output.

8.13 P12 – DC INPUT

P12 is a 2x1 2.54mm pitch, JST B2B-XH-A shrouded connector. It is connected to the Input Power Circuit.

8.15 P13 – EXPANSION POWER CONNECTOR

P13 is an Amphenol HLW16S-2C7LF 16-Pin 1MM Pitch Flex connector. The Pinout for P13 is shown in the following table.

P1 PIN	Name	Description
1	GND	Ground
2	VCC3	+3.3V from On-Board Switching Supply
3	GND	Ground

4	VCC3	+3.3V from On-Board Switching Supply
5	GND	Ground
6	VCC3	+3.3V from On-Board Switching Supply
7	GND	Ground
8	VIN	+12V Input from Input Power Circuit
9	GND	Ground
10	VIN	+12V Input from Input Power Circuit
11	GND	Ground
12	VCC5	+5V from On-Board Switching Supply
13	GND	Ground
14	VCC5	+5V from On-Board Switching Supply
15	GND	Ground
16	VCC5	+5V from On-Board Switching Supply

Table 7 – Expansion Power Connector Pinout

8.15 P14 – USB

P14 is a standard Vertical, USB2.0 Host connector and conforms to the industry standard USB2.0 Pinout. It is connected to the USB2504A USB Hub, Port 3. This connector is not populated by default.

8.16 P15 – I2S OVER HDMI

P4 is a standard HDMI Female connector that carries the Differential I2S signal. Pinout conforms to the PS Audio standards. The Pinout for P4 is shown in the following table.

P15 PIN	Name	Description
1	SDO-	I2S Data Minus
2	GND	Ground
3	SDO+	I2S Data Plus
4	BCK+	I2S Bit Clock Plus
5	GND	Ground
6	BCK-	I2S Bit Clock Minus
7	LRCLK-	I2S Left/Right Clock Minus

P15 PIN	Name	Description
8	GND	Ground
9	LRCLK+	I2S Left/Right Clock Plus
10	MCLK+	I2S Master Clock Plus
11	GND	Ground
12	MCLK-	I2S Master Clock Minus
13	NC	No Connect
14	NC	No Connect
15	W1	Pulled low unless W1 Pin 1-2 Jumper In
16	W1	Pulled low unless W1 Pin 2-3 Jumper In
17	GND	Ground
18	W1	No Connect unless W1 Pin 1-2 Jumper In
19	NC	No Connect

Table 8 – I2S Over HDMI Pinout

8.17 P16 HDMI 1

P16 is a standard Vertical, HDMI connector and conforms to the industry standard HDMI Pinout. It is connected to the CM4 HDMI Port 1. This connector is not populated by default.

8.18 U15 – COMBO RCA/OPTO TRANSMITTER

U15 is a Cliff OTJ6 that contains the RCA for AES COAX digital audio output and a Toslink Transmitter for SPDIF and Optical Digital Audio output.

8.19 D7, D8 – SPEED LED'S

D7 and D8 are Yellow LED's Indicating either 48Khz/96Khz/192Khz Clock Base (D8) or 44.1Khz/88.2Khz/176.4Khz Clock Base (D7).

8.20 SD1 – MICRO-SD CARD

SD1 is a standard Micro-SD Socket and conforms to the industry standard Pinout. It is connected to the CM4 SDIO Port. Non-eMMC modules will boot from this card.

9 DOCUMENT REVISIONS

Date	Revision	Change
10/09/2021	P0.1	Preliminary Release
01/22/2022	P7	Release to match CMA4AES PCB P7
03/11/2022	P8	Renamed CM4AES to Mercury Streamer Updated Power Supply to +12V +/- 20% Added Front and Rear Panel Views Corrected various spelling and grammar errors

Table 9 – Document Revisions

10 ERRATA

10.15 OVERVIEW

The Vertical USB and HDMI Port are not Available for Rev. P7