

# **Pi 2 Design**

**MERCURY V2**

**Hardware Reference Manual**

**© 2023 PI 2 Design**

## Table of Contents

1	Warranty.....	3
2	Operating Specifications.....	4
2.1	MERCURY V2 Operating specifications .....	4
3	Overview .....	5
3.1	Introduction .....	5
3.2	Block Diagram.....	5
4	On-Board Devices .....	7
4.1	Overview.....	7
4.2	Compute Module 4.....	7
4.2	USB2504A usb hub.....	7
4.3	WM8804 SPDIF Transmitter .....	8
4.3.1	WM8804 SPDIF Transmitter Notes.....	8
4.4	Dual High Resolution NDK Clocks.....	9
4.5	RS-485 Differential Transmitter .....	9
4.6	I2S Parallel Buffer.....	9
4.7	I2S Differential Driver.....	9
4.8	Audio Data Rate LED's .....	<b>Error! Bookmark not defined.</b>
5	CM4 Ports and GPIO.....	10
5.1	Overview.....	10
5.2	Compute Module 4 Ports.....	10
5.2.1	CM4 Port Notes .....	10
5.3	Compute Module 4 GPIO.....	10
5.3.1	CM4 GPIO Notes.....	12
6	MERCURY V2 Power .....	13
6.1	Overview.....	13
7	MERCURY V2 Software .....	15
8	Connector Locations.....	16
8.1	Overview.....	16
8.2	Front and Rear Panel and Interior Views.....	16
8.3	Dual USB.....	16
8.4	HDMI 0 and 1.....	17
8.5	Micro-SD Card .....	17
8.5	Gigabit Ethernet.....	17
8.5.16	I2S Over HDMI.....	17
8.6	DIP Switch .....	18
8.7	DC Input Jack .....	18
8.7	TOSLINK OPTO .....	18
8.7	RCA SPDIF.....	18
8.8	XLR AES Balanced.....	18
8.9	BNC AES Single Ended.....	18
8.10	Parallel I2s over RJ45.....	18
10	Document Revisions.....	20
11	Errata.....	21
11.15	Overview .....	21

## List of Figures

Figure 1 – MERCURY V2 Block Diagram .....	6
Figure 2 – MERCURY V2 Power, Simplified Block Diagram .....	13
Figure 3 – MERCURY V2 Power Control Schematic.....	13
Figure 4 – MERCURY V2 Front Panel.....	16
Figure 5 – MERCURY V2 Rear Panel.....	16

# 1 WARRANTY

The enclosed product ("the Product") is warranted by Pi 2 Design for a period of one year for reasonable, individual home use, all as further described and defined below. This warranty runs solely to the individual purchasing the Product and is not transferable or assignable in any respect. This warranty is valid only for so long as the product is used intact as shipped from Pi 2 Design. Any attempt or effort to alter the Product, including but not limited to any attempt to solder, de-solder, unplug, replace, add or affix any part or component of or onto the Product, other than components specifically intended for the user to plug and unplug into appropriate sockets and/or Connectors to facilitate intended use and deployment, all as specifically described and authorized in this Product Hardware Reference Manual, shall void this warranty in all respects. Coverage under this warranty requires that the Product be used and stored at all times in conditions with proper electrostatic protection necessary and appropriate for a complex electronic device. These conditions include proper temperature, humidity, radiation, atmosphere and voltage (standard commercial environment, 0C to +70C, <60%RH). Any Product that has been modified without the express, prior written consent of Pi 2 Design is not covered by this warranty. The use or connection of any adapter or component with any device other than a Pi 2 Design Connector or adapter shall void this warranty and the warranty of all other components, parts and modules connected to the rest of the system. Pi 2 Design shall not be responsible for any damage to the Product as a result of a customer's use or application of circuitry not developed or approved by Pi 2 Design for use on or in connection with the Product.

This warranty does not cover defects caused by electrical or temperature fluctuations or from stress resulting from or caused by abuse, misuse or misapplication of the Product. Any evidence of tampering with the serial number on the Product shall immediately void this warranty. Notwithstanding anything to the contrary herein, Pi 2 Design expressly disclaims any implied warranty of merchantability or implied warranty of fitness for a particular purpose in connection with the manufacture or use of the Product.

## 2 OPERATING SPECIFICATIONS

### *2.1 MERCURY V2 OPERATING SPECIFICATIONS*

MERCURY V2 conforms to the following specifications:

<b>Specification</b>	<b>Value</b>
Dimensions	170mm x 123.2mm x 53.5mm (6.7" x 4.85" x 2.1")
Weight	~1.2kg (3 lbs.)
Storage Temperature	-20C to +85C (-4F to 185F)
Operating Temperature	0C to +70C (32F to 158F)
Humidity	0% to 95% RH, Non-Condensing
Input Voltage (VIN)	+12V +/- 20% DC
Power Consumption	5W Typical, 12W Maximum (not including SSD or USB)

Table 1 – MERCURY V2 Operating Specifications

## 3 OVERVIEW

### 3.1 INTRODUCTION

MERCURY V2 , designed and manufactured by PI 2 Design, is a Compute Module 4 based device designed for Professional, Studio Grade, Digital Audio Streaming. MERCURY V2 converts the Compute Module 4 I2S Interface to High-Definition Digital Audio Coax, OPTO and Balanced XLR. These multiple, simultaneously active digital audio outputs allow MERCURY V2 to optimally interface with virtually any High-Performance DAC on the market.

The major features of MERCURY V2 are as follows:

- **COMPUTE MODULE 4** - This module provides 4 High Performance ARM Cores, Dual 4K HDMI Output, PCIe x1, Gigabit Ethernet, 4/8GB DRAM and more.
- **M.2 2280 SSD** - A Standard M.2 Socket is provided for nVME Storage via the CM4 PCI Express x1 Link. The socket supports both “M” and “B” Key devices.
- **GIGABIT ETHERNET** - A standard RJ45 Provides the interface to the CM4 Gigabit Ethernet I/F.
- **DUAL EXTERNAL USB2.0** - This connector provides two USB2.0 Host Ports.
- **EXTERNAL HDMI** – Two 4K HDMI Connector allows access to CM4 HDMI Outputs 0 and 1
- **AES TRANSMITTER** – The industry standard WM8804 converts the CM4 I2S stream to AES3/SPDIF formatted data at 24-Bit up to 192Khz Frame Rate
- **AES COAX OUTPUT** – A 1:1 Isolation Transformer provides Bit Perfect Impedance Controlled Digital Audio Data @ 1V AES Standard Level.
- **AES BALANCED OUTPUT** – An RS-485 Transmitter with a 1:1 Isolation Transformer provides balanced audio data via the Professional XLR Connector
- **TOSLINK OPTICAL OUTPUT** – Isolated Optical Transmitter Drives Consumer Level DAC’s
- **SPDIF COAX OUPUT** - A 1:1 Isolation Transformer provides Bit Perfect Impedance Controlled Digital Audio Data @ 0.6V Consumer Standard Level.
- **DIFFERENTIAL I2S OUTPUT** – An LVDS Differential Transmitter drives the I2S Bus over an HDMI Connector. Pinout is polarity adjustable for maximum flexibility.
- **PARALLEL I2S OUTPUT** – An RJ45 carries a buffered version of the I2S Bus for short distance use
- **HIGH RESOLUTION CLOCKS** – A pair of Ultra-Low Noise NDK NZ2520SDA oscillators drive the WM8804 in non-PLL mode for the lowest possible noise.
- **ULTRA-LOW NOISE LDO’s** – Two Ultra-Low Noise LT3042 LDO’s (0.9 uV noise and 80 dB PSRR) are used to supply the WM8804 and the NDK Clock’s.
- **LINEAR PRE\_REGULATOR** - LT2941 LDO 5V pre-regulator allows the entire power chain to be linear when an external linear PSU is used.
- **LOW NOISE PCB LAYOUT** – 4-layer Split Ground PCB with noise reduction techniques refined from years of High-Speed Mixed-Signal Design work.
- **EXTRUDED ALUMINUM ENCLOSURE** – Rugged, Aircraft Grade Aluminum, Anodized for Scratch Resistance
- **PRE-PROGRAMMED 32GB SD CARD** - Mercury comes with a 32GB SD Card loaded with Volumio 3.x (other OS's TBD)

### 3.2 BLOCK DIAGRAM

Refer to the following figure for a block diagram of MERCURY V2 .

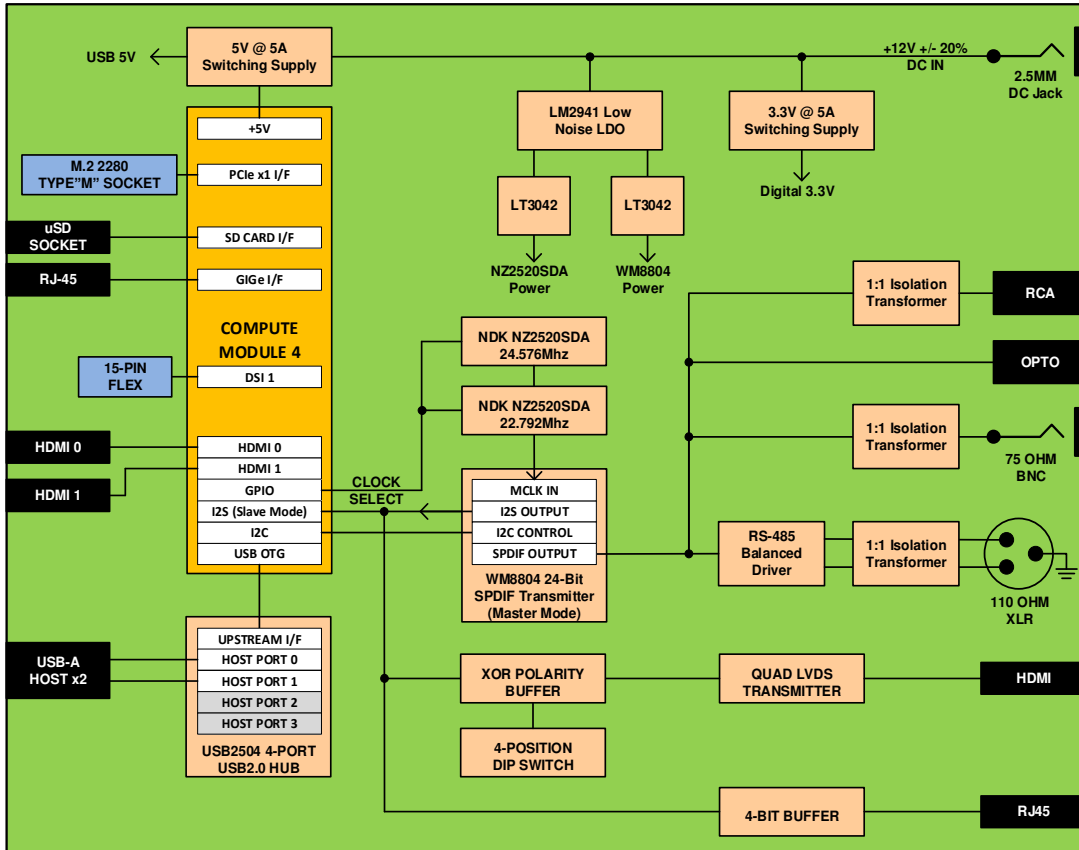

Figure 1 – MERCURY V2 Block Diagram

## 4 ON-BOARD DEVICES

### 4.1 OVERVIEW

MERCURY V2 interfaces to the CM4 via a pair of high density Hirose Connectors. This section describes in detail the devices located on the Mercury Streamer.

### 4.2 COMPUTE MODULE 4

At the core of MERCURY V2 is the latest Raspberry Pi Compute Module 4. Designed for low-powered embedded applications, this module runs the software required to perform the Digital Audio Player function as well as other applications. Key features of the CM4 (as used on the Mercury Streamer) are as follows:

- Broadcom BCM2711, Quad core Cortex-A72 (ARM v8) 64-bit SoC @ 1.5GHz
- H.265 (HEVC) (4Kp60 decode), H.264 (1080p60 decode, 1080p30 encode)
- OpenGL ES 3.0 graphics
- 4GB or 8GB LPDDR4-3200 SDRAM
- 2.4 GHz, 5.0 GHz IEEE 802.11 b/g/n/ac wireless
- Bluetooth 5.0, BLE
- Gigabit Ethernet PHY supporting IEEE 1588
- PCIe 1-lane Host, Gen 2 ( 5Gbps )
- USB 2.0 port
- UART, I2C and I2S Peripheral Ports
- Dual HDMI 2.0 ports (up to 4Kp60 supported)
- 4-lane MIPI DSI display port
- SDIO 2.0

### 4.2 USB2504/A USB HUB

MERCURY V2 uses the Microchip USB2504/A to interface the CM4 with an external dual USB2.0 Connector. The signals of the USB2504/A and their use are described in the following table.

Signal	Connection	Description
USBD_N/P 0	CM4 USB_OTG	Upstream Host port from CM4
USBD_N/P 1	Unused	
USBD_N/P 2	Unused	
USBD_N/P 3	P7 PORT A	Dual USB Host Connector, Lower Port
USBD_N/P 4	P7 PORT B	Dual USB Host Connector, Upper Port

Table 2 – USB2504/A USB Hub Connections

### 4.2.1 USB NOTES

1. The USB Ports are intended for attaching mass storage or USB peripherals. While they can be used to interface with an external DAC, there is no special noise reduction or isolation circuitry.
2. The USB ports on Mercury are USB2.0 with a **MAXIMUM** current output of 1A per port or 1.5A total. While there is over-current protection built in, it is still possible to damage the board plugging in high powered USB devices that are not powered from their own PSU. Please exercise caution. If in doubt use a powered hub in between Mercury and your device.

### 4.3 WM8804 SPDIF TRANSMITTER

At the core of MERCURY V2 is the Cirrus Logic WM8804 AES Digital Audio Transmitter. This device interfaces to the Compute Module 4 via I2S and I2C. The signals used to interface with the WM8804 are shown in the following table.

WM8804 Signal	CM4 Signal	Description
MCLK	-	Unused
BCLK	BCLK	I2S Bit Clock Output to Pi
LRCLK	LRCLK	I2S Word Clock Output to Pi
SDIN	SDOUT	I2S Serial Audio Data Input from Pi
SCL	SCL	I2C Clock from Pi
SDA	SDA	I2C Data to/from Pi
XIN	GPIO6	0 = Select 22.5792Mhz Input Clock for 44.1Khz, 88.2Khz and 176.4Khz Frame Rates 1 = Select 24.576Mhz Input Clock for 48Khz, 92Khz and 192Khz Frame Rates
TXO	-	AES3/SPDIF encoded digital audio output

Table 3 – CM4 to WM8804 Connections

#### 4.3.1 WM8804 SPDIF TRANSMITTER NOTES

3. The WM8804 is controlled using the I2C port. Refer to the WM8804 documentation and installed player software.
4. MERCURY V2 is designed to operate the WM8804 in Master mode. In this mode the WM8804 receives its master clock from XIN and drives



MCLK (unused by the CM4), BCLK and LRCLK out. Serial Data in is received from CM4.

#### ***4.4 DUAL HIGH RESOLUTION NDK CLOCKS***

A pair of NDK NZ2520SDA Ultra-Low Noise clocks provide the critical timing signals for the WM8804. They are selected via Compute Module 4 GPIO6 (0 = 22.5792Mhz and 1 = 24.576Mhz).

#### ***4.5 RS-485 DIFFERENTIAL TRANSMITTER***

An RS-485 Differential Transmitter accepts the SPDIF output from the WM8804 and sends it as a balanced pair to the 1:1 Isolation Transformer and then to the XLR connector.

#### ***4.6 I2S PARALLEL BUFFER***

A 4-Bit Buffer is used to drive the I2S signals (MCLK, BCKL, LRCLK and SDO) to the RJ45.

#### ***4.7 I2S DIFFERENTIAL DRIVER***

A Quad Differential LVDS Driver takes the I2S Bus and converts each signal into a balanced differential signal. This is then connected to an HDMI connector. This device is designed to drive the I2S Bus up to 3 meters.

## 5 CM4 PORTS AND GPIO

### 5.1 OVERVIEW

MERCURY V2 uses several the Interface Ports and GPIO from the CM4 for control and status purposes.

### 5.2 COMPUTE MODULE 4 PORTS

Certain CM4 Port pins are hardwired and are always available when enabled. The usage for these ports on MERCURY V2 are listed below in the following table.

PORT/Signal(s)	MERCURY V2 Use	Description
Ethernet	P8	RJ45 Ethernet Port
*LED_ACT	LED1	Green LED, CM4 Activity
*LED_PWR	LED2	Red LED, Power
Analog_IP0-1	Unused	
Camera_GPIO	Unused	
*EXT_RST	*RST	Reset Out to Peripherals
USB_P/N	USB2504A	USB Host to USB2504A Hub
USB_OTG_ID	GND	Host Mode Only
CAM0-1	Unused	
DSI0	Unused	
DSI1	P5	DSI Interface for LCD Display - unpopulated
PCIe	P9	M.2 2280 NVMe Socket
HDMI0	P4	External HDMI Connector 0
HDMI1	P16	External HDMI Connector 1

Table 4 – CM4 Ports and Usage

#### 5.2.1 CM4 PORT NOTES

1. Ports marked unused are unavailable and not connected on the Mercury Streamer.

### 5.3 COMPUTE MODULE 4 GPIO

The CM4 provides a large number of General Purpose I/O (GPIO) pins. These pins also

can be assigned to alternate functions as defined in the CM4 documentation. The usage of these pins (and alternate functions) on MERCURY V2 are described in the following table.

<b>GPIO</b>	<b>DIR</b>	<b>AF</b>	<b>PUP PDN</b>	<b>Mercury Streamer Usage</b>	<b>Description/Notes</b>
0	I/O	I2C0	PUP	SDA0	Routed to P5 for DSI 0
1	I/O	I2C0	PUP	SCL0	Routed to P5 for DSI 0
2	I/O	I2C1	PUP	SDA	I2C Data for MERCURY V2 and Expansion
3	I/O	I2C1	PUP	SCL	I2C Clock for MERCURY V2 and Expansion
4	-			unused	
5	-			unused	
6	I/O			GPIO6	WM8804 Master Clock Select
7	-			unused	
8	-			unused	
9	-			unused	
10	-			unused	
11	-			unused	
12	-			unused	
13	-			unused	
14	-			unused	
15	-			unused	
16	-			unused	
17	-			unused	
18	IN	I2S		BCLK	I2S Bit Clock from WM8804
19	IN	I2S		WCLK	I2S Word Clock from WM8804
20	-			unused	
21	OUT	I2S		SDOUT	I2S Serial Data to WM8804
22	OUT		PUP	PHLD	Power Hold to Power Circuit

<b>GPIO</b>	<b>DIR</b>	<b>AF</b>	<b>PUP PDN</b>	<b>Mercury Streamer Usage</b>	<b>Description/Notes</b>
23	-			unused	
24	-			unused	
25	-			unused	
26	-			unused	
27	-			unused	

Table 5 – CM4 Port and GPIO Pin Assignments

### **5.3.1 CM4 GPIO NOTES**

2. DIR is from the point of view of the CM4.
3. Alternate Function (AF) column indicates that the use of this pin requires the pin to be assigned to the named function as defined by the CM4 specifications.
4. PUP/PDN indicates if the GPIO should have its associated Pullup (PUP) or Pulldown (PDN) resistor enabled.
5. An asterisk ‘\*’ at the beginning of the name indicates a low true signal.

# 6 MERCURY V2 POWER

## 6.1 OVERVIEW

MERCURY V2 is designed to be powered from an external +12V source.

See the block diagram below for a simplified view of MERCURY V2 power flow.

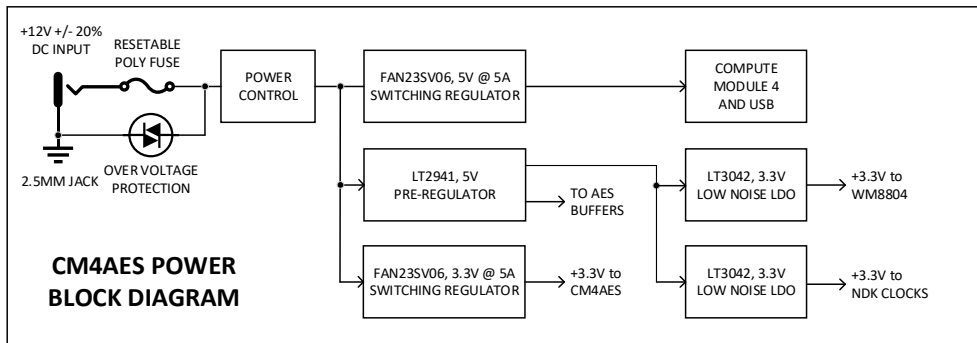

Figure 2 – MERCURY V2 Power, Simplified Block Diagram

## 6.2 POWER CONTROL

This circuit allows software to monitor and control the power state of the Mercury Streamer. It uses two GPIO to perform the Power Hold and Power State functions. This circuit is compatible with the Volumio 503HTA Plug-In. Note that by default the circuit simply follows the state of the Pushbutton Power Switch.

This circuit is shown in the figure below.

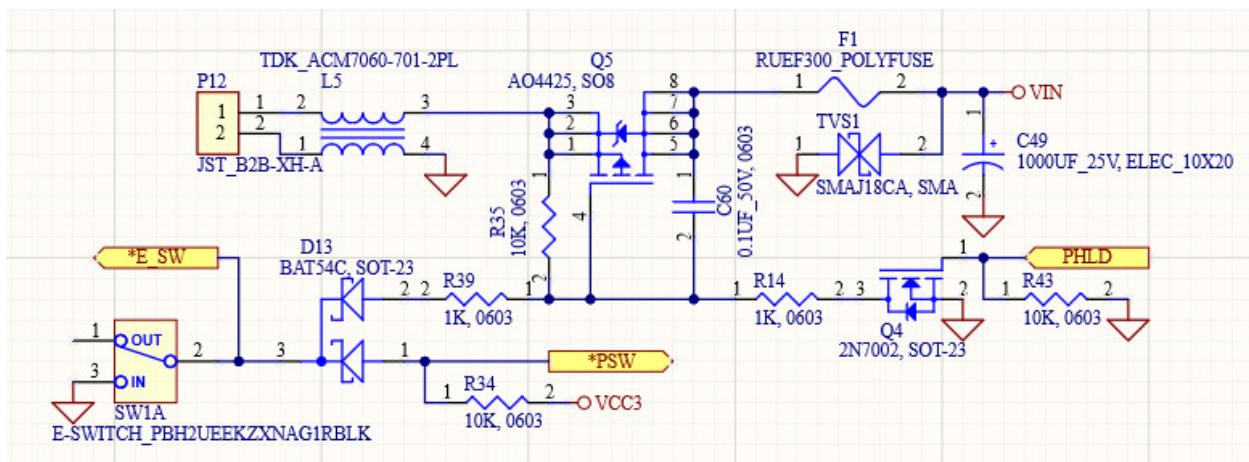

Figure 3 – MERCURY V2 Power Control Schematic

### ***6.3 POWER STATUS***

As part of the power control circuit, GPIO24 (\*PSW) is used to sense the state of the Pushbutton Power Switch. A low indicates that the Power Switch is in the on position (depressed). When high it indicates that the user has placed the switch into the off position (non-depressed) thus opening the on/off switch. Note that for proper operation this circuit requires user software to program GPIO24 as an input with the internal pullup enabled.

### ***6.4 POWER HOLD***

GPIO22 (PHLD) allows the CM4 to hold the power on even after the user puts the Power Switch into the off position. After initialization, software can drive GPIO22 high, thus holding the power on regardless of the state of the on/off switch. Driving this low, removes this hold condition. Note that for proper operation this requires user software to program GPIO24 as an output with the internal pullup disabled.

## 7 MERCURY V2 SOFTWARE

### *7.1 OVERVIEW*

Due to the various resources interfaced on the Mercury Streamer, both internal and external to the CM4, it is necessary to initialize a large number of CPU registers and external devices before correct operation can begin. These values and their proper sequencing are beyond the scope of this document.

### *7.2 COMPATIBLE DRIVER*

Most Audio Player software will support Mercury using either the “Pi2design PI2AES” or “HifiBerry Digi+ Pro” driver.

### *7.3 USB HOST*

Unlike the Raspberry Pi 4, the CM4 ROM Firmware does not enable the USB Host functionality by default. It is necessary to initialize this by adding the following line to `cfg_boot.txt`. Note that some player software will over-write this during an update but may offer an alternate location that is safe from updates.

To enable the USB 2.0 ports on the Compute Module 4, you need to edit the boot config file (`/boot/config.txt`) and add:

```
dtoverlay=dwc2,dr_mode=host
```

### *7.4 PCIE SSD CONFIGURATION*

This section is %TBD%

## 8 CONNECTOR LOCATIONS

### 8.1 OVERVIEW

This section provides the type, location, and pinout for the various connectors on the Mercury Streamer.

### 8.2 FRONT AND REAR PANEL AND INTERIOR VIEWS

This shows the front and rear panels of MERCURY V2 as well as an internal view of the PCB.

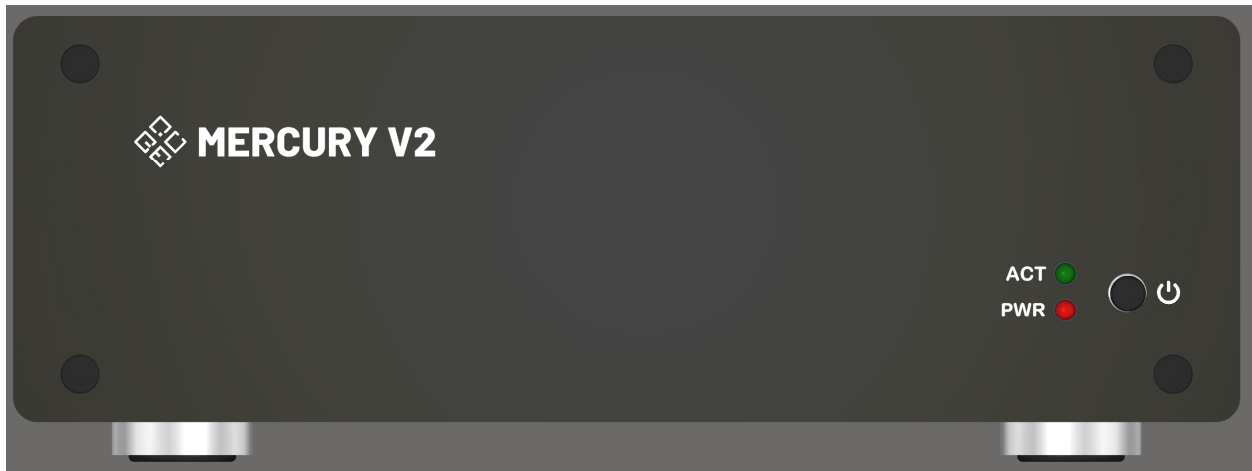

Figure 4 – MERCURY V2 Front Panel

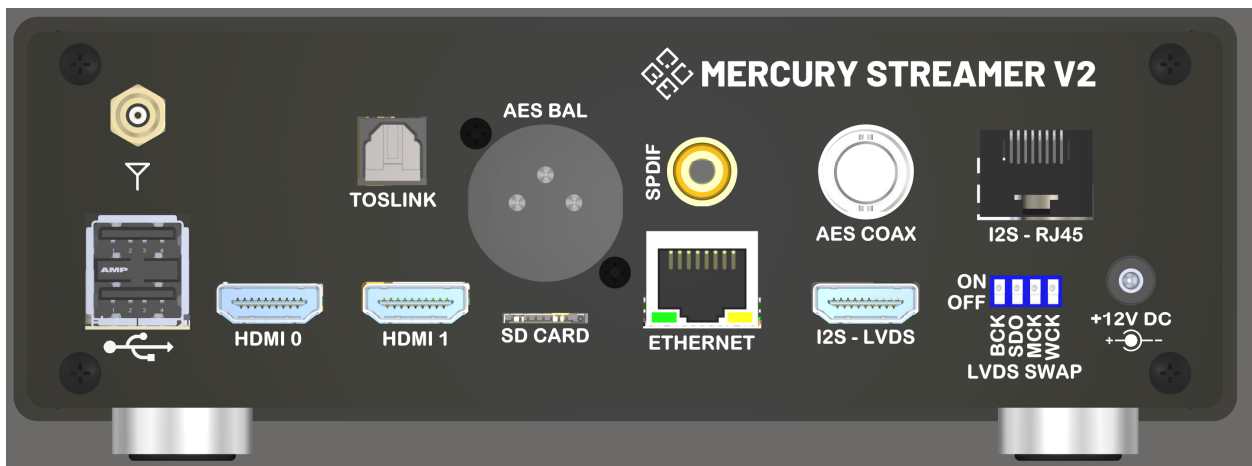

Figure 5 – MERCURY V2 Rear Panel

### 8.3 DUAL USB

This is a standard Dual USB2.0 Host connector and conforms to the industry standard



USB2.0 Pinout. It is connected to the USB2504A USB Hub, Ports 3 (top) and 4 (bottom).

#### **8.4 HDMI 0 AND 1**

HDMI 0 and 1 are standard right angle HDMI female connectors and conforms to the industry standard HDMI Pinout. They are connected to CM4 HDMI Ports 0 and respectively.

#### **5.15 MICRO-SD CARD**

SD1 is a standard Micro-SD Socket and conforms to the industry standard Pinout. It is connected to the CM4 SDIO Port.

#### **8.5 GIGABIT ETHERNET**

This is a standard CAT5 RJ45 and conforms to the industry Pinout. It is connected to the CM4 Ethernet Port.

#### **5.16 I2S OVER HDMI**

This is a standard HDMI Female connector that carries the Differential I2S signal. Pinout conforms to the PS Audio standards. The Pinout for this connector is shown in the following table.

<b>P15 PIN</b>	<b>Name</b>	<b>Description</b>
1	SDO+	I2S Data Plus (Minus when DIP Switch 2 is on)
2	GND	Ground
3	SDO-	I2S Data Minus (Plus when DIP Switch 2 is on)
4	BCK+	I2S Bit Clock Plus (Minus when DIP Switch 1 is on)
5	GND	Ground
6	BCK-	I2S Bit Clock Minus (Plus when DIP Switch 1 is on)
7	WCK+	I2S Word Clock Plus (Minus when DIP Switch 4 is on)
8	GND	Ground
9	WCK-	I2S Word Clock Minus (Plus when DIP Switch 4 is on)
10	MCK+	I2S Master Clock Plus (Minus when DIP Switch 3 is on)
11	GND	Ground
12	MCK-	I2S Master Clock Minus (Plus when DIP Switch 3 is on)
13	NC	No Connect

P15 PIN	Name	Description
14	NC	No Connect
15	P15	Pulled to GND with 10K ohm resistor
16	P16	Pulled to GND with 10K ohm resistor
17	GND	Ground
18	+5V	Connected to +5V via 100 ohm resistor
19	NC	No Connect

Table 6 – I2S Over HDMI Pinout

**8.6 DIP SWITCH**

This 4-position switch allows each I2S LVDS signal to have it’s polarity swapped when in the ON position. Refer to the table above.

**8.7 DC INPUT JACK**

This is a 2.5MM Center Positive DC Jack.

**5.17 TOSLINK OPTO**

This carries the Optical TOSLINK digital audio output

**5.18 RCA SPDIF**

This RCA connector carries the SPDIF digital audio output

**8.8 XLR AES BALANCED**

This 3-pin connector carries the Balanced AES Digital Audio output.

**8.9 BNC AES SINGLE ENDED**

This right-angle BNC 75-ohm female connector carries the Single Ended AES Digital Audio output.

**8.10 PARALLEL I2S OVER RJ45**

This 8-pin RJ45 carries a buffered version of the I2S Bus for short distance (<3M) use. The Pinout for this connector is shown in the following table.

P15 PIN	Name	Description
1	SDO	I2S Data
2	GND	Ground

<b>P15 PIN</b>	<b>Name</b>	<b>Description</b>
3	WCK	I2S Word (Left/Right) Clock
4	GND	Ground
5	BCK	I2S Bit Clock
6	GND	Ground
7	MCK	I2S Master Clock
8	GND	Ground

Table 7 – Parallel I2S Over RJ45 Pinout

## 10 DOCUMENT REVISIONS

Date	Revision	Change
10/09/2021	P0.1	Preliminary Release
01/22/2022	P7	Release to match CMA4AES PCB P7
03/11/2022	P8	Renamed CM4AES to Mercury Streamer V2 Updated Power Supply to +12V +/- 20% Added Front and Rear Panel Views Corrected various spelling and grammar errors
04/06/2023	P2	Corrected default Polarity for SDO and L/R CLK, also changed L/R_CLK to WCLK and fixed other naming errors

Table 8 – Document Revisions

# 11 ERRATA

## *11.15 OVERVIEW*

The Vertical USB and HDMI Port are not Available for Rev. P7